

ACCESSORY INSTALLATION

With diverter valve for hand shower on slider rail

Please note that the wall plugs supplied are only suitable for solid stone / brick walls. For plasterboard walls use specialist wall plugs.

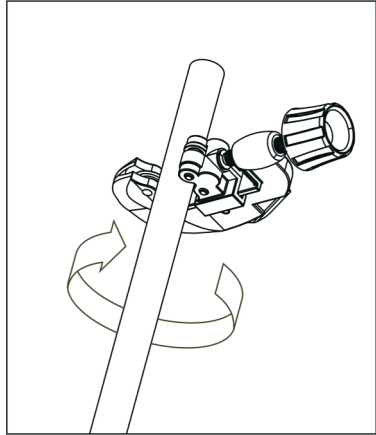

1. This rail can be adjusted in height by cutting the rail tube to the preferred length. Do so BEFORE assembly.

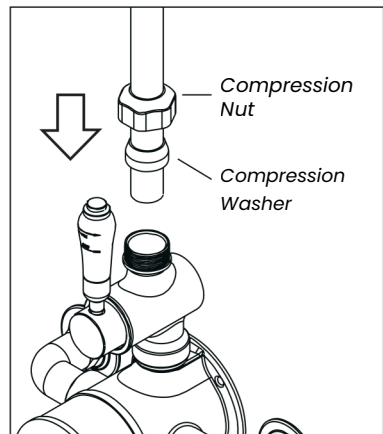
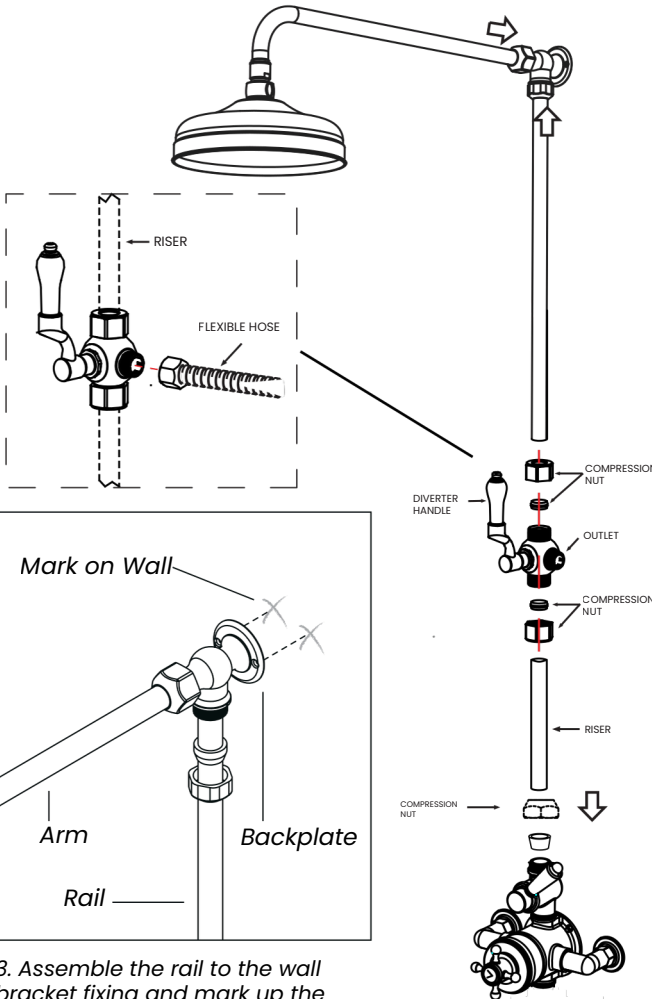

2. Secure the rail to the valve using the compression fitting at the valve body

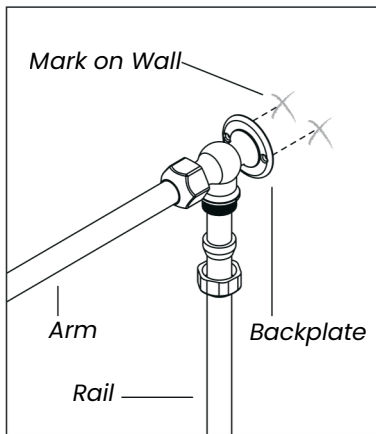

3. Assemble the rail to the wall bracket fixing and mark up the fixing holes for wall attachment

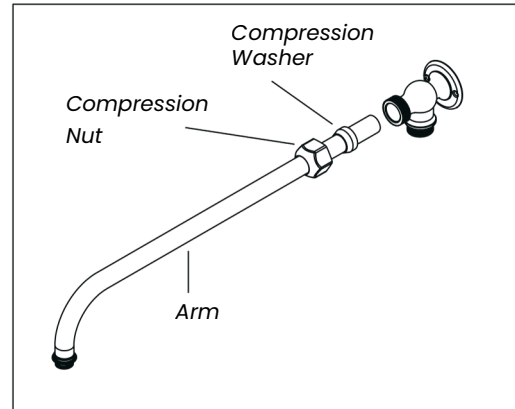

4. The arm can also be adjusted in length by disassembling the elbow fixing and cutting the arm to the preferred length.

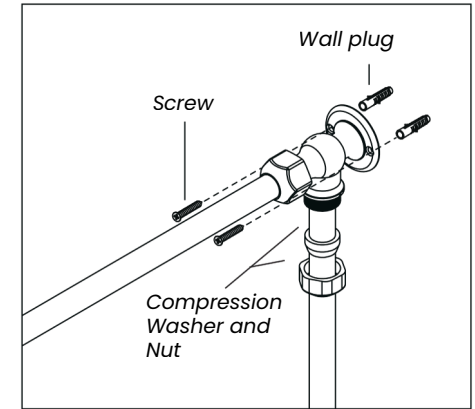

5. Re-insert the arm and screw the backplate tight to the wall (WITH DUAL FUNCTION VALVE MAKE SURE HANDSET HOLDER IS PUT ONTO THE RAIL BEFORE FIXING IN PLACE)

OPERATING

1. Turn the water flow control handle to increase/decrease the flow and turn on/off.

2. Turn the temperature control handle to increase/decrease the water temperature.

3. The temperature control knob is pre-set to auto stop at above 44°C to avoid scalding. However, if for any reason the setting is removed it is important to follow "Temperature Setting" procedure to reset.

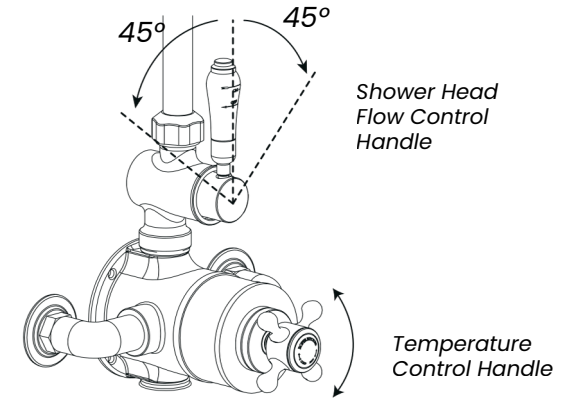

ACCESSORY INSTALLATION

Without diverter valve for hand shower on slider rail

Please note that the wall plugs supplied are only suitable for solid stone / brick walls. For plasterboard walls use specialist wall plugs.

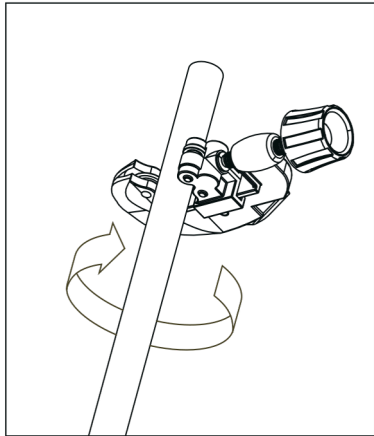

1. This rail can be adjusted in height by cutting the rail tube to the preferred length. Do so BEFORE assembly.

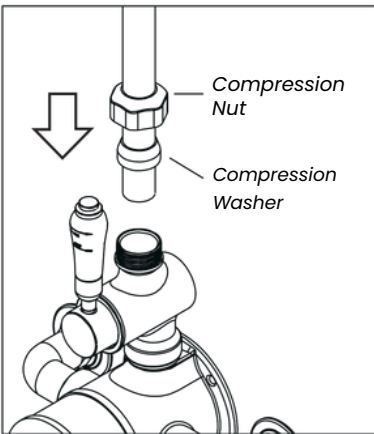

2. Secure the rail to the valve using the compression fitting at the valve body

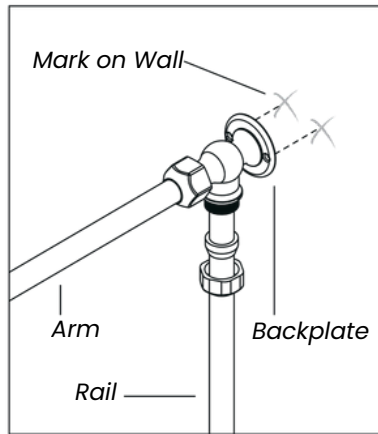

3. Assemble the rail to the wall bracket fixing and mark up the fixing holes for wall attachment

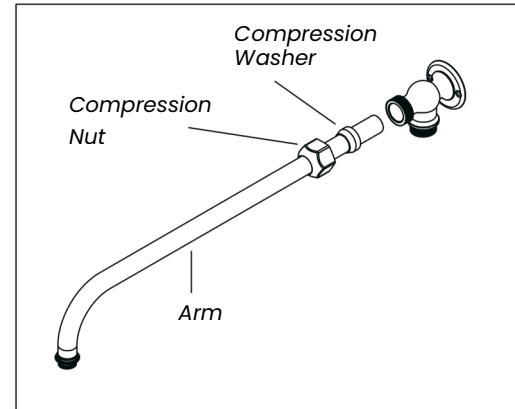
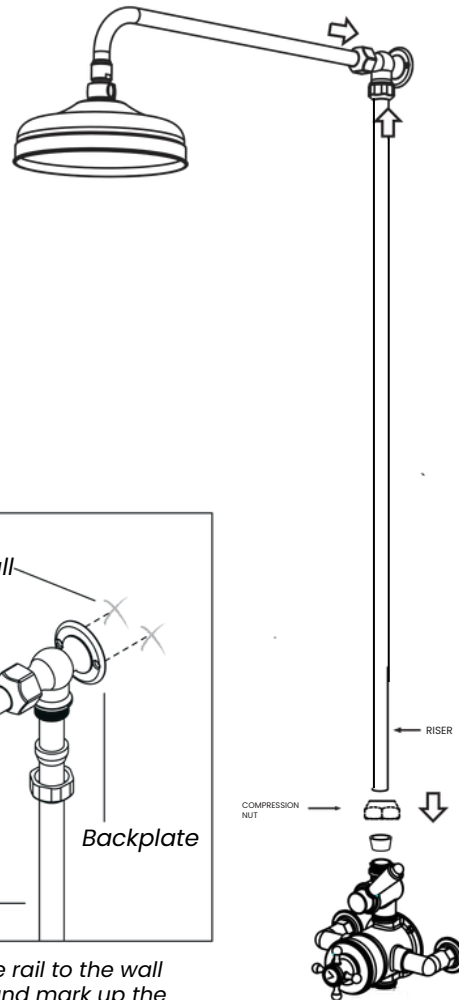

4. The arm can also be adjusted in length by disassembling the elbow fixing and cutting the arm to the preferred length.

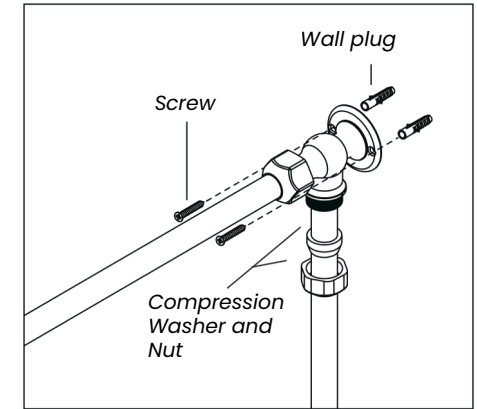

5. Re-insert the arm and screw the backplate tight to the wall (WITH DUAL FUNCTION VALVE MAKE SURE HANDSET HOLDER IS PUT ONTO THE RAIL BEFORE FIXING IN PLACE)

OPERATING

1. Turn the water flow control handle to increase/decrease the flow and turn on/off.

2. Turn the temperature control handle to increase/decrease the water temperature.

3. The temperature control knob is pre-set to auto stop at above 44°C to avoid scalding. However, if for any reason the setting is removed it is important to follow "Temperature Setting" procedure to reset.

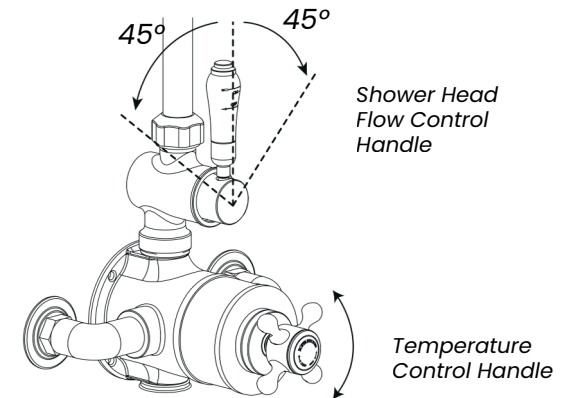

INSTALLATION

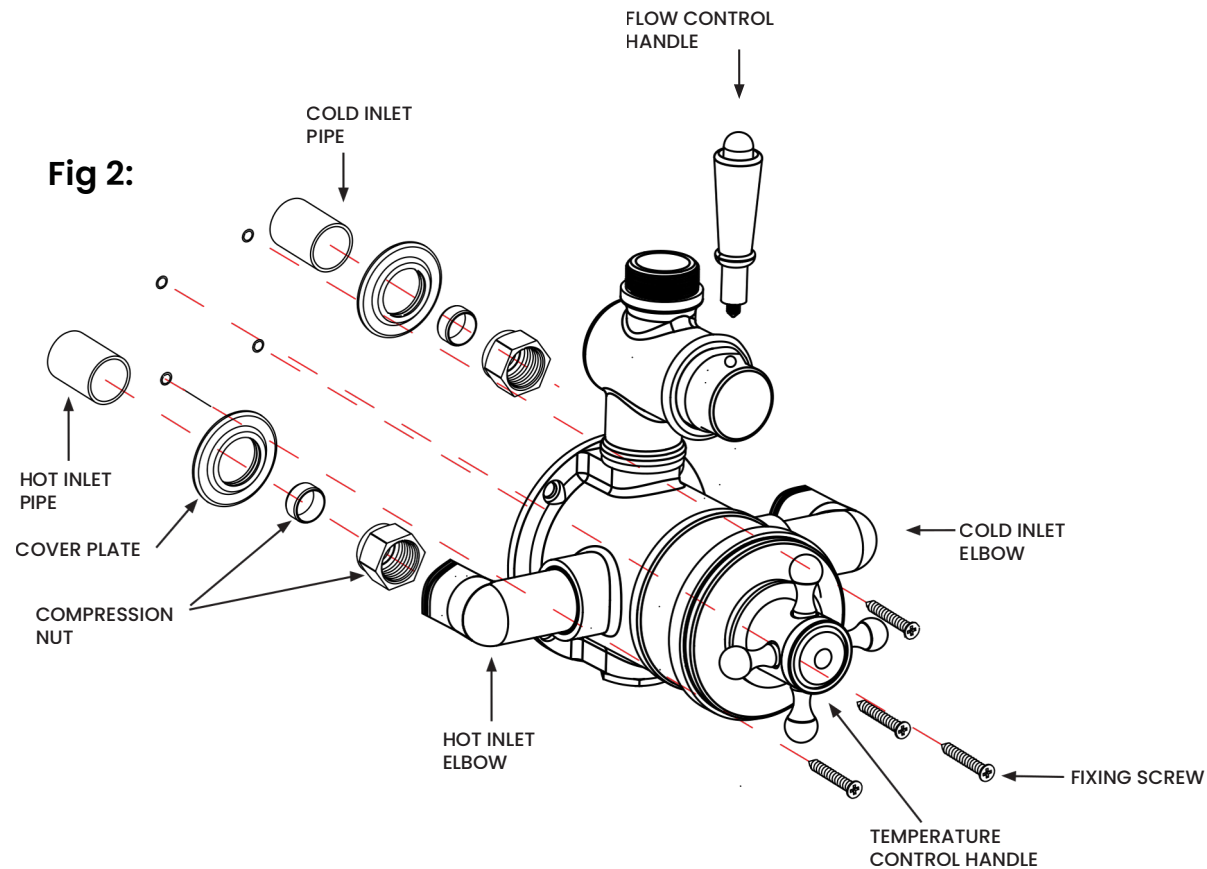
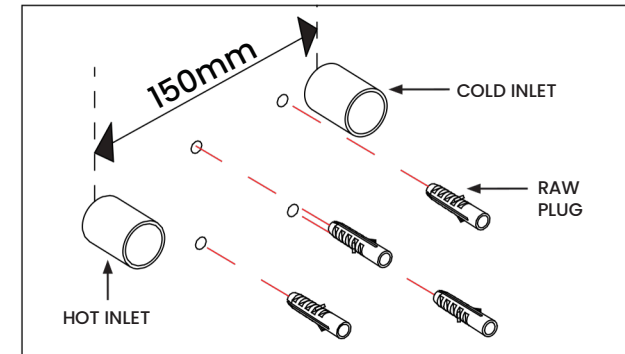

Fig 1:



1. Prepare the water supply pipes (hot on the left and cold on the right) at the identified height with a width of 150mm centres.
2. Make the ends of pipes 20-25mm out from the face of wall.
3. Remove the compression nuts and the plates from the inlet elbows of valve.
4. Put the back plate onto the wall and mark the position of 4 holes.
5. Drill 4X8mm holes on the wall to a depth of 45mm and insert wall plugs.
6. Fix the back plate and valve to the wall with the supplied screws.
7. Slide the cover plates under the compression nuts and position each pipe with the cover plate against the wall.
8. Push the valve over the inlet pipes.
9. Tighten the two compression nuts on both inlets.

INSTALLATION INSTRUCTIONS

After identifying a suitable place on the wall for the slide rail kit, you need to install the slide rail first

1. Put two back plates on the wall and mark the position of 4 holes
2. Drill 4X8mm holes on the wall to a depth of 45mm and insert wall plugs
3. Fix the back plates and side rail to the wall with the supplied screws

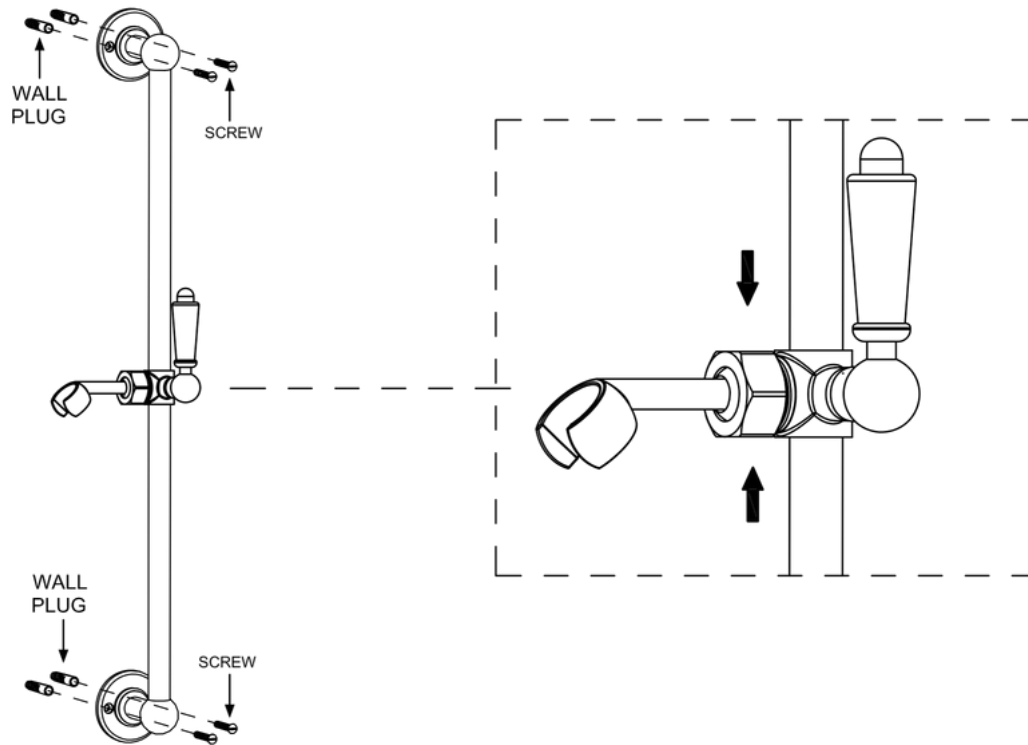

Connect the water supplier pipe to the tail

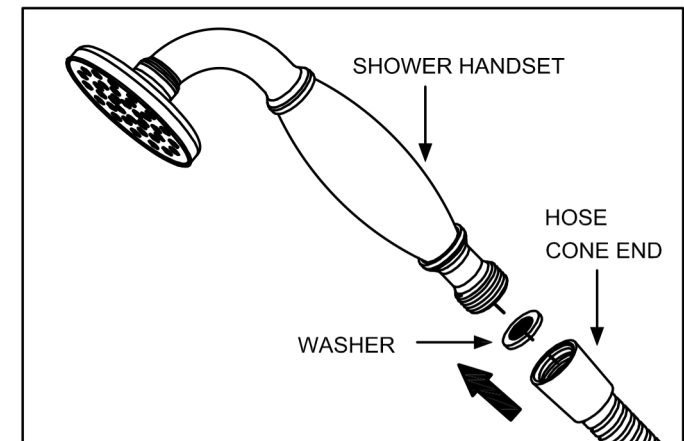

INSTALLATION INSTRUCTIONS

Important

- We recommend that this product is installed by a qualified professional contractor
- Please check this product immediately to ensure that it has not been damaged and is complete. Before installation, please make sure this product is the correct model and you have all the parts required for installation and using
- Please read these instructions carefully and keep it for future reference

Maintenance

We do not recommend you use any household cleaners to clean the product because these cleaners change substance or formula too frequently. The product should be cleaned only with soapy water and rinsed with clean water and dried with a soft cloth.

Dimension

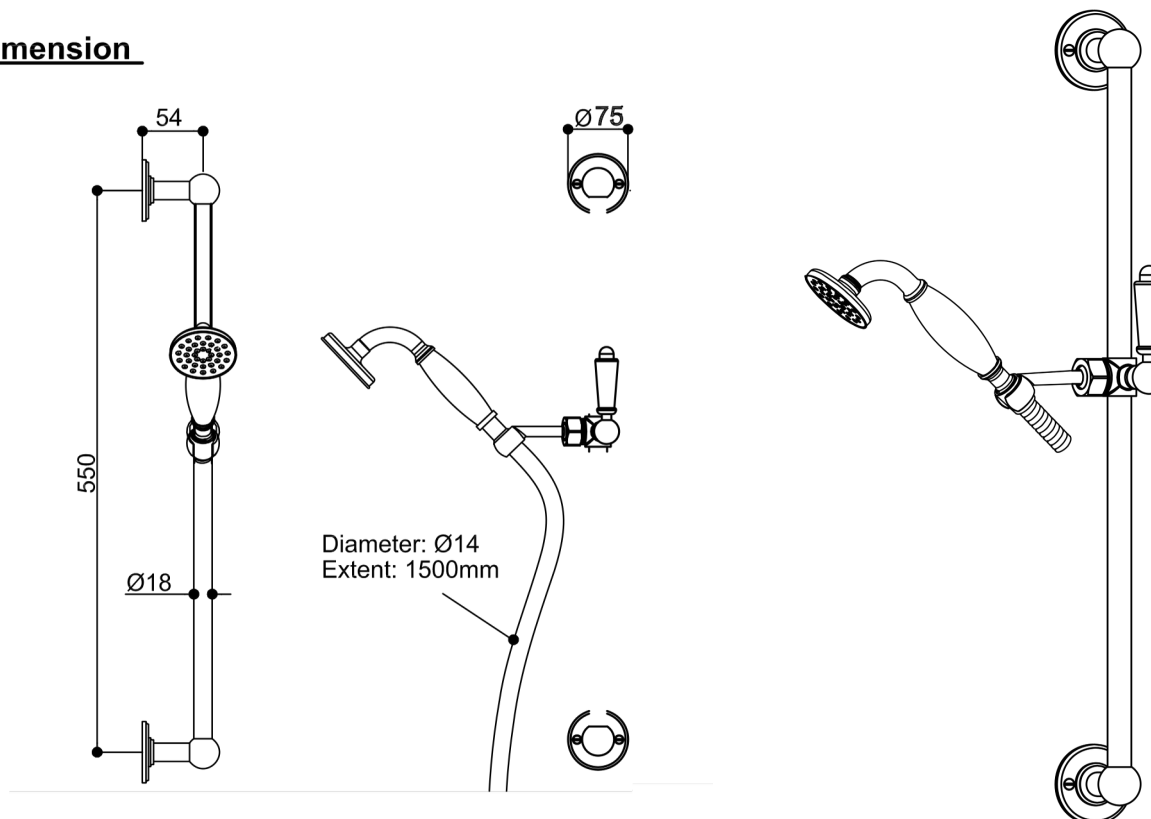

Conditions for the use of thermostatic mixing valve

The thermostatic valve has been designed to be compliant with the relevant UK standards applicable to this type of product governed by TMV2 standards and WRC. This product Conforms to BS EN 1111.

The valve can function under low pressure; however, it is recommended that the cold water supply has a minimum height of 2 meters above the shower valve outlet.

- This thermostatic valve is suitable for all water systems with a maximum operating pressure of 5.0 bar. For higher pressures, we recommend installing pressure-reducing valves.
- The valve features a single top outlet, controlled by a flow control cartridge. It is typically used with a main shower head or a flexible shower kit when paired with a diverter valve.
- The use of independent, flexible hot and cold water supply pipes is recommended to facilitate ease of maintenance.
- If a shower pump is being installed, it must be positioned before the shower valve. The recommended limits for correct operation are listed below.

	Low Pressure
Maximum Static Pressure - Bar	10 Flow Pressure
Flow Pressure, Hot & Cold - Bar	0.2 to 5
Hot Supply Temperature - °C	55 to 65
Cold Supply Temperature	Equal to or less than 25

The British Burns Association advises a bathing temperature of 37–37.5°C for children. In premises subject to the Care Standards Act 2000, the maximum mixed water outlet temperature is set at 43°C.

Important

- Before commencing work, ensure the water supply is turned off at the inlet isolating valves (if fitted) or at the main stopcock.
- Installation of this product is recommended to be carried out by a qualified professional contractor.
- Upon receipt, please check the product to ensure it is free from damage and complete. Prior to installation, verify that the model is correct and that all necessary components are included.
- As this valve functions as a mixing device, it requires reasonably balanced water supplies. If this condition is not met, the installation of a pressure-reducing valve is recommended.
- Prior to commissioning, the water system should be flushed to prevent metal swarf, solder, and other contaminants from entering the valve.
- Please read these instructions carefully and keep it for future reference.